



# Wood Words

Kansas City Woodworkers Guild [www.kcwoodworkersguild.org](http://www.kcwoodworkersguild.org)

Volume 22 Issue 12

December 04

Guild Meetings:  
Jacob's Well Church,  
1617 W. 42nd St.,  
KC Mo. 64111

**2005 Dues can begin being paid this month thru the end of Feb 2005**

## DIRECTORS-OFFICERS:

**President:** Wayne Wainwright  
816 453-1073  
[wwrig@kc.rr.com](mailto:wwrig@kc.rr.com)

**Vice President:** Wayne Suter  
816 628-4602  
[wlsuter@earthlink.net](mailto:wlsuter@earthlink.net)

**Secretary:** Dave Roth  
913 338-2433  
[chefroth@everestkc.net](mailto:chefroth@everestkc.net)

**Treasurer:** Paul Twenter  
816 781-9407  
[paul@twenter.com](mailto:paul@twenter.com)

**Events:** Mike Jones  
816 204-6406  
[sportsturf@kc.rr.com](mailto:sportsturf@kc.rr.com)

**Communication:** Brian Kemp  
816 455-8892  
[b.kemp@earthlink.net](mailto:b.kemp@earthlink.net)

**Sponsorship:** Neal Shoger  
816 781-4000  
[nrshoger@swbell.net](mailto:nrshoger@swbell.net)

**Membership:** Terry Stair  
816 765-7296  
[tandkstair@aol.com](mailto:tandkstair@aol.com)

**Training:** Ken Sokol  
913 441-6060  
[kensokol@yahoo.com](mailto:kensokol@yahoo.com)

**Education:** Chuck Slagle  
913 402-8336  
[slaglecs@earthlink.net](mailto:slaglecs@earthlink.net)

**Video**  
Don Kruse

**Books**  
George Rexroad

**Editor/Web:**  
Wayne Wainwright

## December Raffle: Chris will have his usual assortment of fine tools!

Please thank sponsoring members; noted below for supporting our Guild.

**Next Meeting Wed. December 15th, 7 PM**

**Program: Christmas party**

### Sawdust: The Presidents Corner

*Wayne Wainwright*



Thanks to Chuck Slagle for a very interesting program last month.

If I am honest with myself, I do not follow safety precautions enough. After that program, I have re-committed myself to shop safety in every way.

I just updated my fire suppression gear and purchased some new goggles and safety glasses. I will pay closer attention to keeping myself safe in the shop so I can continue doing what I love for many years to come.

On that note, it has been 20 years! That is the theme of the meeting this month. For 20 great years, the Kansas City Woodworkers Guild has been in existence.

This month is a celebration of that event. Bring your significant others and enjoy our time together in remembrance.

We will have food and drink and lots of merriment this month.

Also, some of our members will be specially recognized for their service to the guild over the years.

Make sure you have your 2 X 4 project and your unfinished CRP projects.

As promised last month, here is an accounting of what we have accomplished this year on the goals front. Here are items we have completed or are ongoing:

- Involve members in setting direction of the Guild
- Publish guild financial status in newsletter

- Formalize the Mentor workshop program
- Support Craftsman Recognition Program
- Conduct member

### PLEASE PATRONIZE OUR SPONSORING MEMBERS



**Paxton Woodcrafters**  
**(816) 483-0659**



**PlansNow**  
**[www.PlansNOW.com](http://www.PlansNOW.com)**



**Schutte Lumber**  
**(816) 753-6262**



**Turn-About-Wood**  
**(816) 587-3195**



**Woodcraft Supply**  
**(913) 599-2800**



**Elmwood Reclaimed Timber**  
**(816) 532-0300**



**Professional Tool Mfg LLC**  
**(913) 599-2800**



**Accent Merchandising**  
**(816) 635-5792**

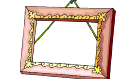

**The Framery**  
**(913) 831-9411**



**Strasser Hardware**  
**(816) 236-5858**



**Liberty Hardwoods**  
**(816) 231-0852**



**Wood By Design**  
**(913) 962-0159**

surveys for improving Guild activities and guild leadership

- Begin guild “Leadership Development” program
- Improve relationship with Guild sponsors
- Begin Guild training classes for our members
- Grow Sponsorship program (currently 11)

Here are items that are still “works in progress”

- Begin Guild training classes for non members
- Formalize our community involvement programs
- Double the size of the Guild

We have grown the Guild by 50% but we did not double the size just yet. Our trend is good and we are coming into the traditionally highest period for recruitment so I am confident we will hit the number just not as soon as I had targeted.

Note: For the first time in at least 10 years however, we will start the new year with a higher number of members than we ended the previous year which is a great sign we have turned the corner!

Thanks to all of you who have given out a business card or mentioned us to a friend. You make the difference.

- Let’s have a safe and happy holiday season.
- Let’s remember our friends and our friendships.
- Let’s remember those who are less fortunate than ourselves
- Let’s have fun in everything we do. Happy holidays to all!

## **Program: Shop Safety with Chuck Slagle**

David Roth

Wayne Suter introduced Chuck Slagle and he asked the guild a question. Who has done anything at all in their shop to break a safety rule this week?

A lot of hands went up. Chuck Slagle has been a safety professional for thirty years and has a master’s degree in Industrial safety. Chuck works at Sprint as a safety manager. He talked about things that are there to protect you.

Chuck encourages us to look at the Guild website and look for the fact sheets on safety.

How do you recognize hazards in your shop? To protect yourself against a hazard, you have to understand the hazard.

### **EYE AND FACE PROTECTION**

- Flying objects, chips,
- Wood kick back
- Impact damage from the kick back
- Dust
- Chemicals
- Noise

These are things what we want to avoid. Nobody wants to walk away from his or her shop with an injury. Certainly not missing a digit or certainly not from injury to your eye.

### **EYE INJURY**

Safety Glasses:

Chuck suggested getting some safety glasses that fit you. Make sure they are comfortable. Safety glasses come in all sizes and styles. You have blows, chemicals and flying particles that can hurt your eyes. When you are buying safety glasses for eye protection what do you look for?

They should be adequate for the hazard. If you were turning, you would use safety glasses and a face shield. The face shield protects you from flying particles. If your safety glasses always fog up

and you and you put them down all the time, you need to find a pair that are comfortable and won't fog up on you.

If your safety glasses are scratched throw them out. Chuck has gone on safety inspections and looks at the safety glasses and they are all scratched up. Throw them out. You are not going to wear them anyway; because you can't see. Get new ones.

Personal protection equipment is no good if you don't use it on the job or in the shop.

If you have employees in your shop, the first thing you need to do is make sure they wear personal protection equipment. Give them a selection to choose from to make sure they fit comfortably.

### **PRESCRIPTION SAFETY GLASSES**

If you have a safety frame you'll see a Z 87 on the template. If you do not have that information on your glasses you do not have safety glasses.

You want polycarbon to be used for your safety glasses. Real glass breaks. Wal-Mart, Target, sell safety glasses as does US safety on 87th street.

### **CHEMICAL GOGGLES**

These will protect you against splashes. If you have the chemical goggles that have a lot holes in them "those are not chemical goggles"! Chemical goggles wrap all the way around so chemicals cannot get in.

### **FACE SHIELDS**

Chuck has found these at Home Depot at a good price.

### **GLOVES**

Provide good protection for your hands from scrapes and abrasions. A good pair of leather gloves are good for carrying around plywood to prevent splinters. They save your hands from mechanical injuries.

There are vinyl, latex and Nitrile gloves. Nitrile is a purple glove. Nitrile gloves create a barrier between your skin and chemicals. It will protect your hands from staining.

Nitrile gloves don't break apart like latex gloves and vinyl gloves when using stain and other chemicals.

### **RESPERATORS**

Chuck likes to see certification on the respirator. He suggests - before you use a respirator, consult with your doctor - if you have trouble breathing now and then, when you start sucking through a fiber mesh on a respirator you will have to take a lot more stress on your heart and your lungs. You need to make sure your doctor checks and see if you can do this.

The little thin respirators are masks.

If it has two straps Chuck calls this a respirator.

N 95 is the type you want. It has an exhale valve. These don't protect vapors or gases. But protects from dust.

### **NOISE PROTECTION**

Chuck passed out earplugs to our guild members.

### **EAR MUFFS / EAR PLUGS**

They protect you from the harmful noise that can damage your ears. Like a loud Shopvac running.

Plugs are o.k. To use but they are a one time thing. Semi Inserts put pressure on the inside of the ears. Ear Muff is what Chuck likes to use.

NRN "Noise Reduction Rating" is a single number

### **Special Member Benefit from:**

**Plans NOW**

Join the PlansNOW Treasure Hunt and win TOOLS!  
Visit PlansNOW.com and click on the PlansNOW Pirate for details.

And while you're there, use your 15% discount on all the plans and techniques in the store.

**Your e-coupon word is: KCGuild**

Read more about our newest Sponsor on our web site or visit them at: **www.PlansNOW.com**

rating.

Higher the number the better the noise reduction. First with earmuffs you have to subtract 25 % off of the NRR number label. With ear plugs you have to subtract 50 % off of the NRR Number label. Semi Inserts you have to subtract 70 % off of the NRR number label.

Try and have some type of ear protection. Long time exposure to loud noise from the shop can contribute to loss of hearing. It's personal protection equipment of what feels good for you and what works for you.

**Thanks Chuck - very enlightening!**

### Shop Safety

#### Think your Drill is pretty safe?

While working on a mouse trap car for school, I was holding the bottom of the Lego car and the top of the mouse trap.

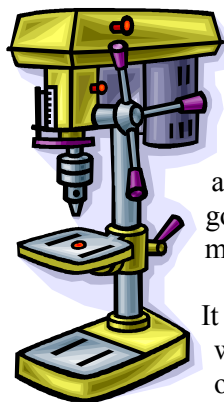

While drilling, it went through quite fast. Since it was going fast it went right through where I was holding it and the bit went into my finger. It didn't go completely through my finger, but made a nice little hole.

It bled a lot and I was near fainting. I washed it out for a while, put pressure on it and then put a band aid on and had to change it a lot. But, in the end I was pretty much ok

**Advice to other woodworkers:** Pay attention to what you are doing.... watch were your fingers are.

I was using a corded hand drill to put a hole in the inside top of a doorway (the hole was for an alarm system switch that would activate when the door was opened).

I was standing on a ladder looking up at the drill above my head. Once the bit took, the sawdust began to fly and got in my eyes. I wasn't wearing safety glasses, so to avoid more sawdust I looked down while continuing to drill.

Unfortunately, I was too close to the drill, and my hair came in contact with the chuck. Before I knew it the chuck had completely wound itself into my hair and drew my

head snug up against the drill, pinning my hand on the trigger.

I could release the pressure on the trigger enough to turn the drill off, but I could not get my hand off the drill, nor my hair out of the chuck. A coworker came over and unraveled me. I wasn't hurt bad, but the drill had scalped me, leaving a 1" by 6" bald spot right down the middle of my head.

**Advice to other Woodworkers:** Wear safety glasses, keep power tools well away from your body and your hair, don't wear loose clothes or jewelry while working with power tools.

I placed a 17" long "used" wood boring bit into the chuck to drill through 12.5" thick glue laminate. After supporting the laminate and turning on the drill press (proper RPM, all safety precautions taken) and preparing to enter the wood, the bit bent 90 degrees just an inch under the chuck, where the bit met the shank.

The bit whipped around several times before I could shut it down, and in the ensuing adrenaline rush I had not noticed that the tip of the bit had ripped a rather large hole in my shirt and left a nasty deep scratch across my chest and sternum.

The bit had been lent to a "friend" and came back seemingly in fine shape. I suspect that it had been bent, and then bent back straight. It worked just fine for several hundred revolutions while I fine tuned my setup, and was nowhere near contact with wood when it decided to bend. It is a bit of a mystery to me exactly what caused this.

**Advice to other Woodworkers:** I would advice woodworkers to:

- Never loan tools
- Never become complacent about safety, I was convinced that I had taken all of the "necessary" precautions, but clearly I had not
- Never get into a situation where you are wondering about the limitations of the equipment... if there is even a question about "Can this be done?" you probably have no business trying to do it.

## Shop Tip

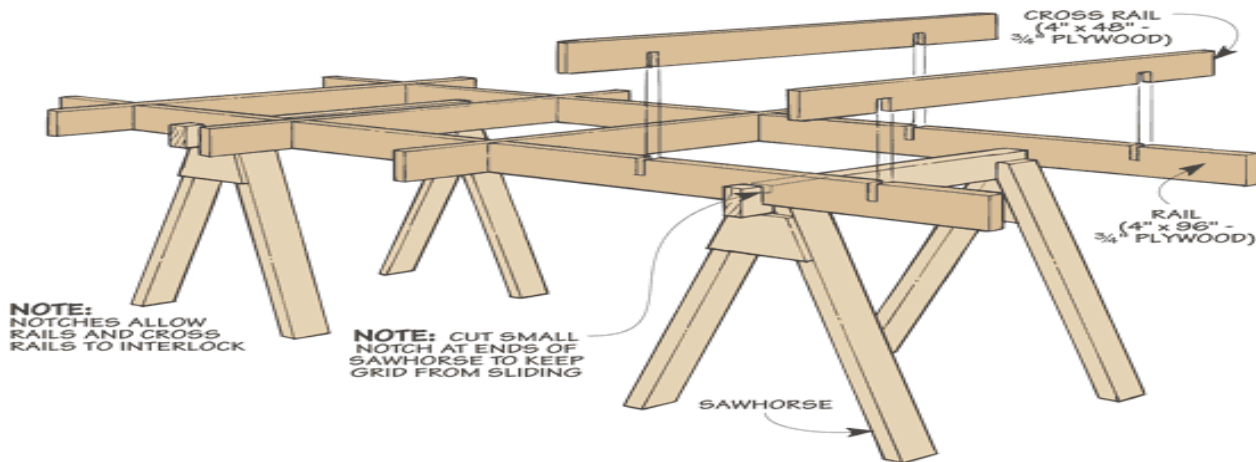

**NOTE:**  
NOTCHES ALLOW  
RAILS AND CROSS  
RAILS TO INTERLOCK

**NOTE:** CUT SMALL  
NOTCH AT ENDS OF  
SAWHORSE TO KEEP  
GRID FROM SLIDING

SAWHORSE

### Knock-Down Sawhorse Cutting Grid

Cutting down full sheets of plywood with a circular saw has always been a bit awkward.

I usually lay the plywood sheet on supports on the floor and then have to crawl around to make the cut.

But recently, I came up with a solution that makes the process a lot easier.

I made a simple cutting grid that fits over a pair of sawhorses, see drawing above. The grid is made up of interlocking strips of  $\frac{3}{4}$ " plywood. The strips are all 4" wide. I cut two 8-foot long strips for the main rails and five 4-foot long strips for the cross rails. Then all the strips are notched so that they interlock to create a grid. I also notched the bottom edge of the long strips and the top edge of the sawhorses to hold the grid in place.

The grid is assembled on top of the sawhorses by simply sliding the pieces together. Then I put the sheet of plywood on top of the grid and set the blade on my saw so that it cuts through the plywood and just barely starts to cut into the top edges of the grid. (If the rails get chewed up through use, it's a simple matter to make some new ones.)

The nice thing about this cutting grid is that when I'm finished cutting, it can be disassembled and stored out of the way.

### Router Bushing Thread Lock

When routing dovetails, I use a guide bushing on the

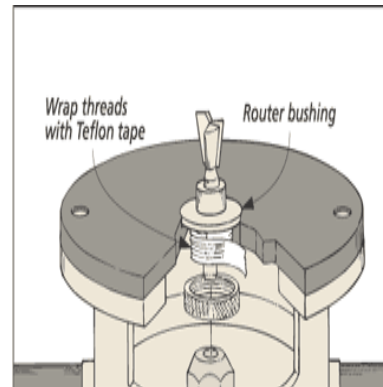

base plate of my router. But the vibration of the router can sometimes cause the threads of the bushing to work loose. So I came up with a simple fix for the problem.

Now I install the bushing on the base plate, I wrap the threads with Teflon tape as shown in

the drawing. This is the kind of tape plumbers use to seal pipe threads. Since I've been using this trick, I haven't had any problems with the bushing coming loose.

Printed by permission of: © August Home Publishing Co.

All rights reserved. For more tips like this, visit:

[www.WoodworkingTips.com](http://www.WoodworkingTips.com)

Want to help cut guild monthly costs? Consider receiving the newsletter via email. It is faster and comes in color. If you are interested, please send an email to Wayne Wainwright at: [wwrig@kc.rr.com](mailto:wwrig@kc.rr.com), or add your email to the Attendance list at the monthly meetings.

**Newsletter Deadline: 1st of the month:**

Please send all submissions for articles, tips, want ads announcements and anything else to Wayne Wainwright: 816 453-1073 email: [wwrig@kc.rr.com](mailto:wwrig@kc.rr.com)

4214 N Brighton Ave KC. MO. 64117

### Member of the Year

Brian Kemp

#### Jim Bany



As you know, for the first time this year, we have asked all of the “members of the month” for previous months to vote on one of their own to select a Member of the Year.

select a Member of the Year.

The members have overwhelmingly selected Jim Bany for that honor. His many contributions to the guild and the interesting projects he has brought to Show and Tell were the reason I am sure.

Here is some of Jims work.

Congratulations Jim for being recognized as a leader among your peers!



# Show & Tell - Show Pictures



**Frank Layne - Wood Clocks**



**Trent Glamann - Cherry Cabinet**



**Parker Nelson - White Oak project**



P.O. Box 413922  
Kansas City, MO. 64141

### Meeting Minutes

**New Members / Visitors:** Visitors - James Hamilton and Jean Butler. New member - Hubert Wilburn

#### **News:**

Don't forget the 2 X 4 contest in December!

The large raffle item is different this month: The Shop Starter

- Delta 6 piece cordless combination set, Finish mauler, Circular saw, Scroll Saw, Drill, Sander, Flashlight, 1 ½ horsepower Porter cable Router with 2 collets ¼ inch and ½ inch, Set of Marples chisels with a small Mallet, Set of 19 piece Forstner Bits 150-bit drill set. At 135 degree angles, Smoke alarm, 6 horsepower wet dry shopvac and rolling cart to go with it

#### **Toy Project**

Terry stair reported that 100 benches are finished.

Fred Chael has 600 dragster ready to go.

**Current Budget:** \$3,901.80

#### **Tool Talk:**

Jim Bany purchased a PLS 2 level. It levels horizontal and vertical at the same time. Cost? \$300.00

Dave Kraatz demonstrated holding boards together with corner blocks. Dave makes his own corner blocks. Dave saw some at the tool show for \$12 a piece. Dave found a good deal at his hardware store and purchased a package of corner brackets that come in different sizes around \$3 a pair. Dave suggests keeping a few around the workbench. They come in handy when trying to clamp things together or to mark dovetails out.

#### **Raffle:**

Dan Hurley won the chisel set, Phillip Gram takes the level laser set, Wayne Wainwright won the drill, David Roth won the 19 piece stubby tool set and an extension cord, Chris Kunzle won the drill clamp, John Maciel Won a drill bit set

### Show and Tell:

**Frank Lane** Made two clocks from the December issue of Wood Magazine made of cherry that have a spray lacquer finish. It took him about 1.5 hours to complete the two clocks.

**Anthony Harris** brought in some turnings:

He brought in a bowl turned "cross grain" and made from aromatic cedar. He burned the edge on it and it has a lacquer finish.

Anthony also made a "Donut box". It has 16 threads to the inch

### Calendar

Executive Meetings, 7:00pm Kansas City Public Library 1410 W 10th St. KC MO 64105

Guild meetings, 7:00 p.m., Jacob's Well Church, 1617 W. 42nd St., To reach us "during the meetings, call: KCMO. (816) 561-8177

#### **Executive Meetings**

#### **Guild Meetings**

**2004**

January 20th  
February 17th  
March 16th  
April 20th  
May 12th  
June 9th  
July 14th  
August 11th  
September 8th  
October 13th  
November 10th  
December 8th

January 21st  
February 18th  
March 17th  
April 21st  
May 19th  
June 16th  
July 21st  
August 18th  
September 15th  
October 20th  
November 17th  
December 15th

All members are welcome at any board meeting. A call to one of the Officers is all that is necessary.

and has a hole in the middle to hold a necklace and bracelets. It is made from African black wood and is finished with carnauba Wax. Anthony bought the African black wood from Canada. From a clarinet factory.

He also brought in a "Circle box" made from a Palm Nut. He made it into a pedestal box. Anthony made a bud for it and then he put a nice tall finial on it. Anthony also teaches wood turning classes at Woodcraft.

**Parker Nelson** made a project from scraps using mortise and tenon joinery with quarter sawn white oak and a Minwax stain and polyurethane.

**Trent Glamann** made a Cherry Cabinet with an oil urethane finish on it.